

Hudson Reed

Parete Doccia in Vetro Scanalato

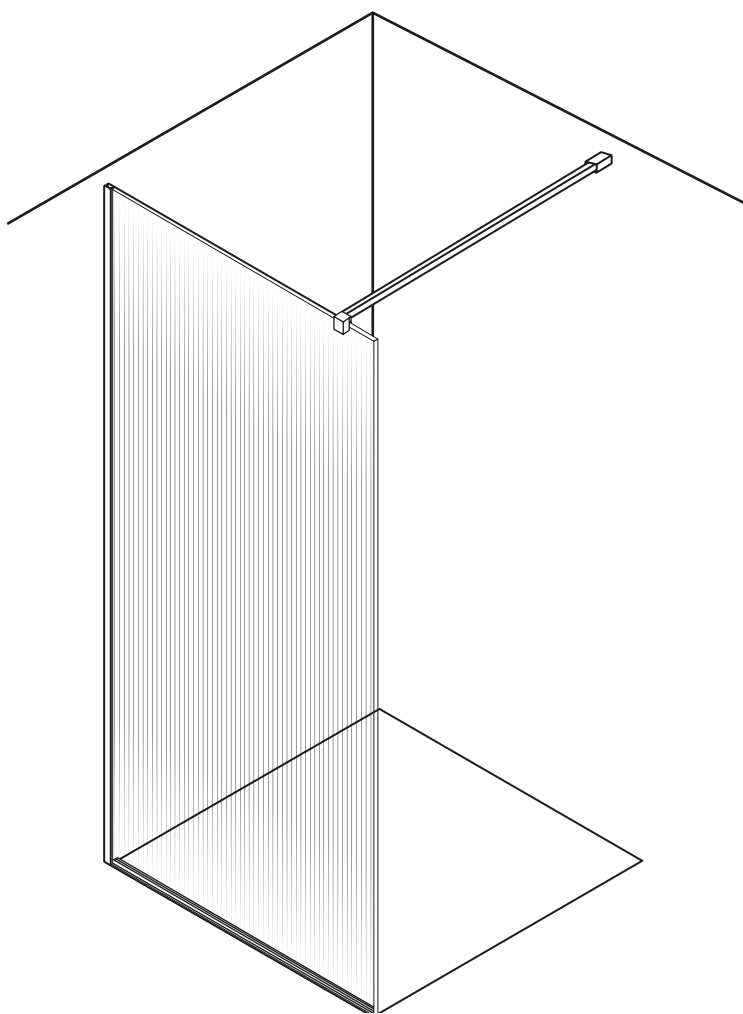

 Lo stile potrebbe variare

Guida di installazione



- Il vetro temperato (EN12150) delle nostre cabine doccia e pareti vasca è completamente sicuro a condizione che venga installato con cura e secondo le guide fornite.
- Prima di iniziare l'installazione, controllare attentamente il prodotto per assicurarsi di aver ricevuto tutto in buon ordine. Se avete dubbi riguardanti il prodotto, i suoi contenuti o questa guida, contattateci per consentirci di assistervi. Si consiglia inoltre di coprire sufficientemente la zona circostante e gli infissi prima di effettuare l'installazione per proteggerli da eventuali danni accidentali.
- È necessario prestare attenzione durante la manipolazione e l'installazione di questo prodotto, eventuali urti violenti, maneggio improprio o forti fluttuazioni di temperatura potrebbero causare lo sviluppo di un punto di stress al suo interno. Per motivi di salute e sicurezza, l'installazione deve essere eseguita da due persone competenti, ad esempio installatori qualificati assicurati, e devono essere utilizzati indumenti e attrezzature protettivi adeguati.
- Il vetro temperato è intrinsecamente fisicamente e termicamente più resistente del vetro standard per garantirne la sicurezza per l'uso in bagno. Nell'improbabile caso in cui il vetro si rompa a causa dei motivi sopra indicati, lo farà in piccoli frammenti.

CONTROLLO PRE-INSTALLAZIONE

- Assicuratevi di aver ricevuto il prodotto corretto facendo riferimento alle etichette sulla confezione del prodotto.
- Controllare attentamente il contenuto della confezione prima dell'installazione.
- Prestare particolare attenzione quando si disimballa il contenuto della confezione, in particolare i componenti in vetro temperato.
- Controllare attentamente tutti i componenti ricevuti per eventuali danni o difetti prima di iniziare l'installazione: non possiamo accettare responsabilità per eventuali difetti o danni riscontrati una volta iniziata l'installazione.
- Prima di iniziare l'installazione, leggere e comprendere tutte le istruzioni fornite con il prodotto.
- Assicuratevi che non vi siano tubi o cavi nascosti prima di eseguire qualsiasi foratura.
- Non tentare di apportare modifiche al vetro di sicurezza temperato stesso poiché ciò potrebbe danneggiarlo.

Installazione

Strumenti richiesti per l'installazione:

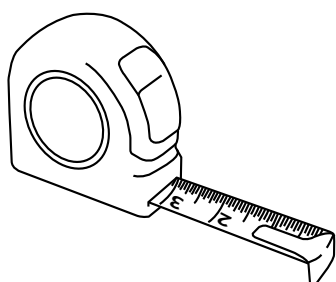
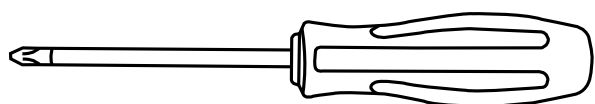
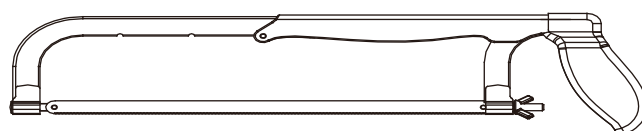
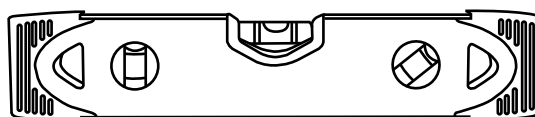
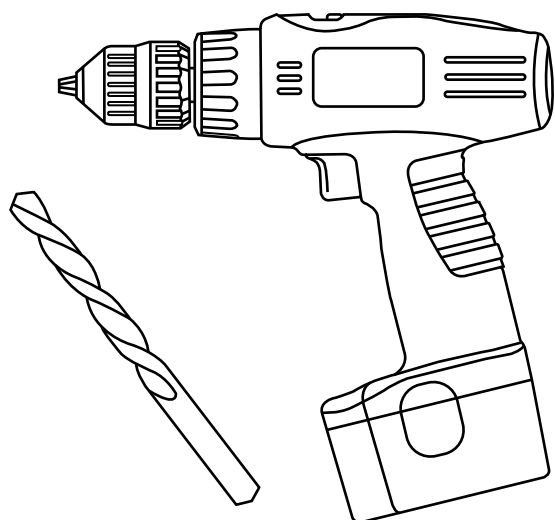
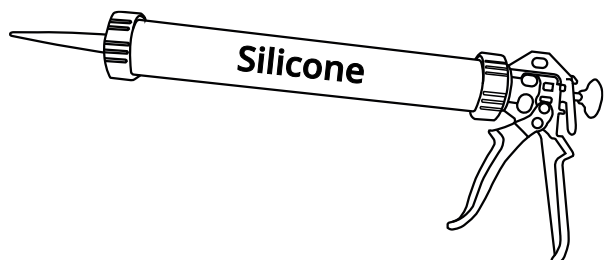

Installazione

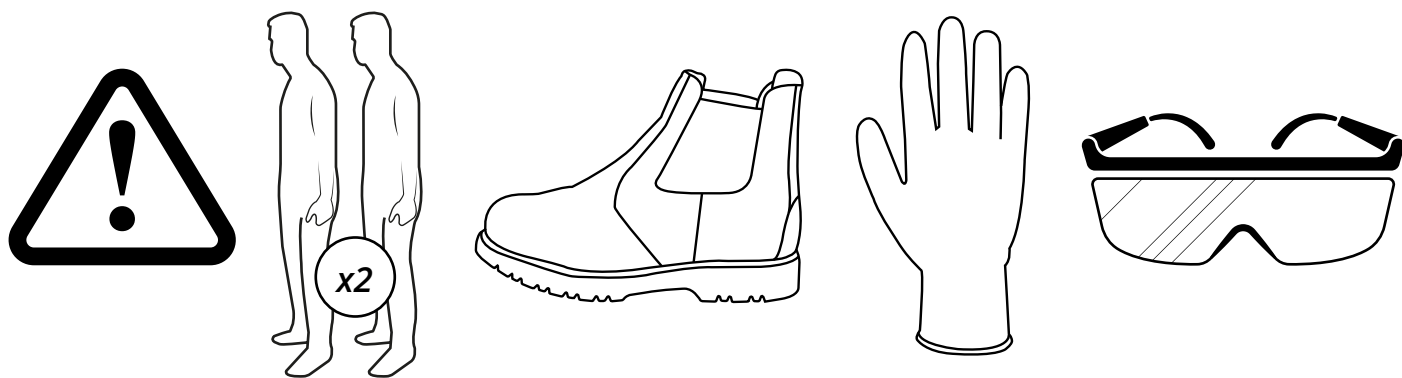

Parti incluse:

A
x6

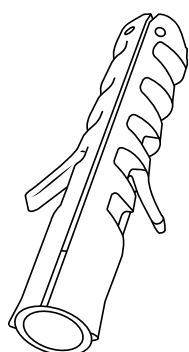

B
x6

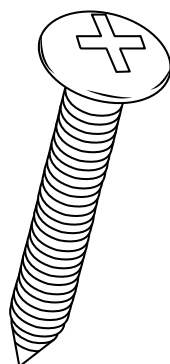

C

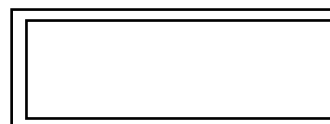

D

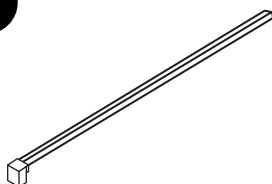

E

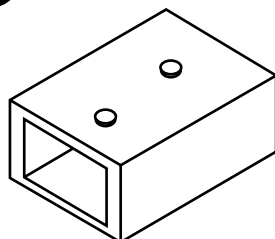

F

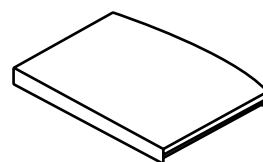

G

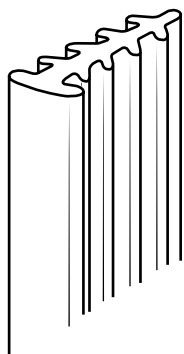

1

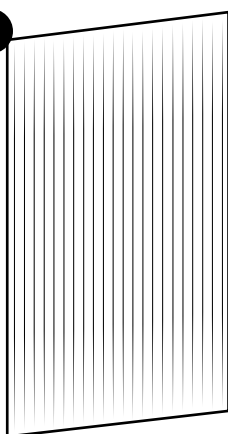

i Opzionale

H

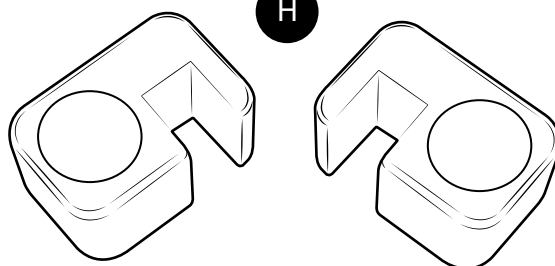

Mano sinistra - Mano destra

1

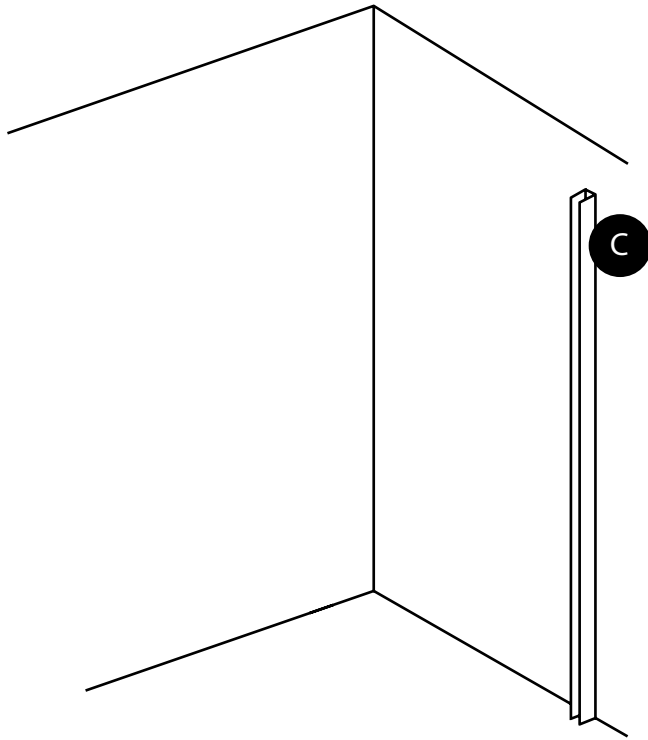
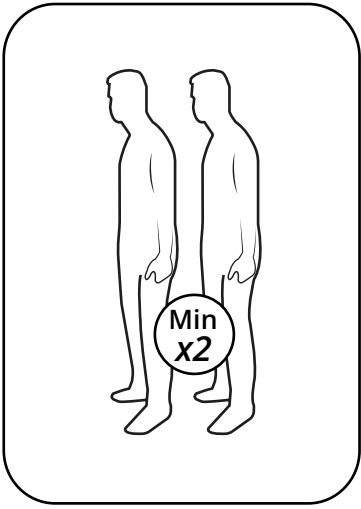

2

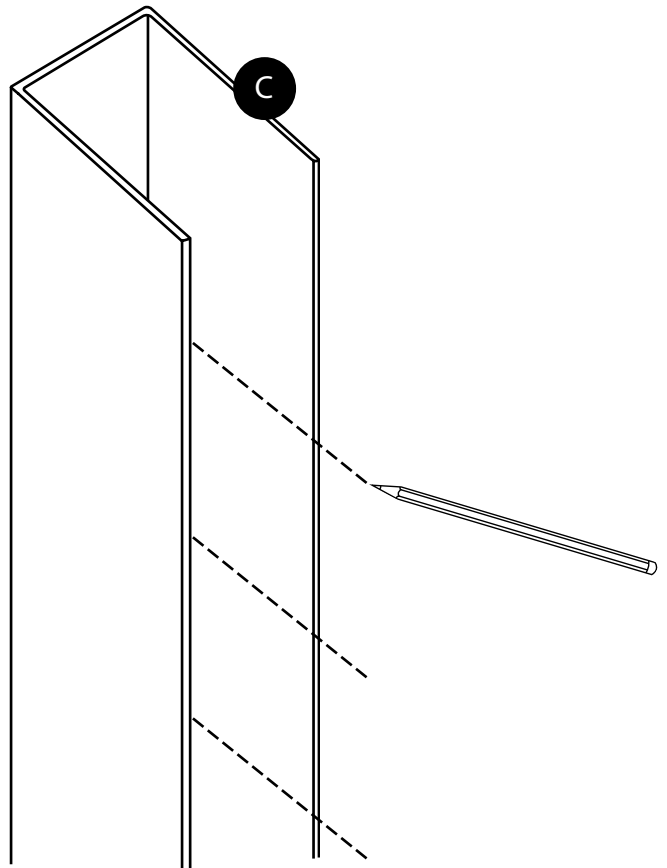
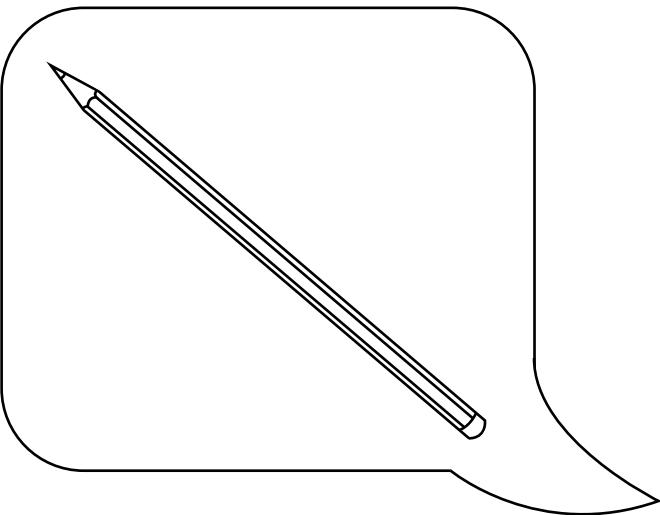

3

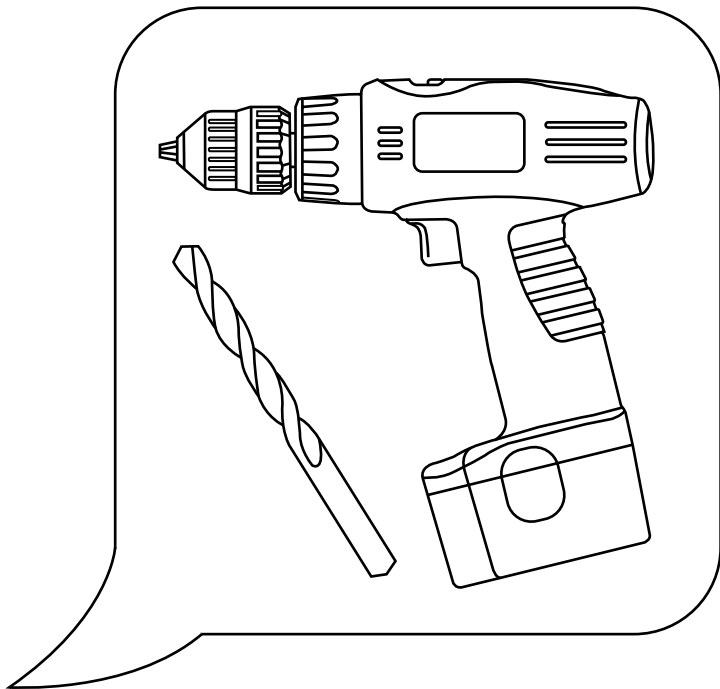
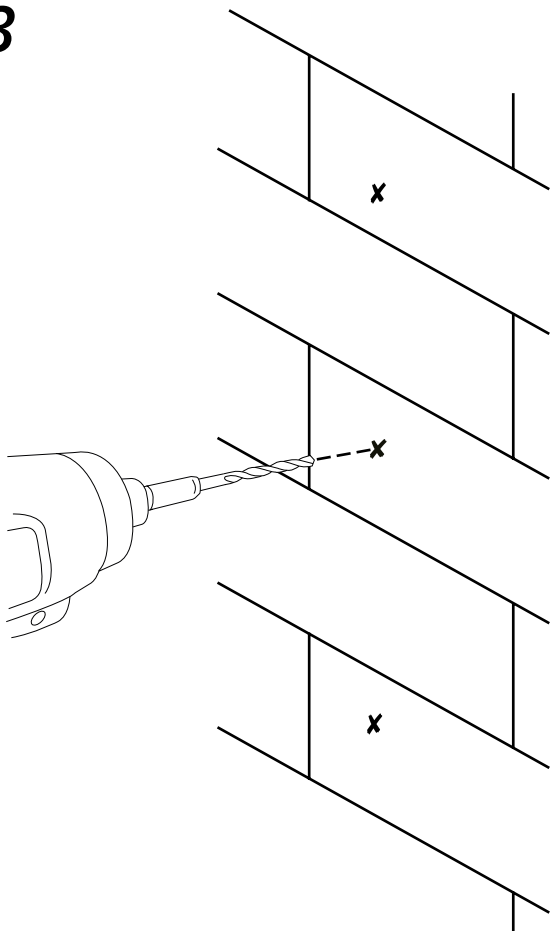

4

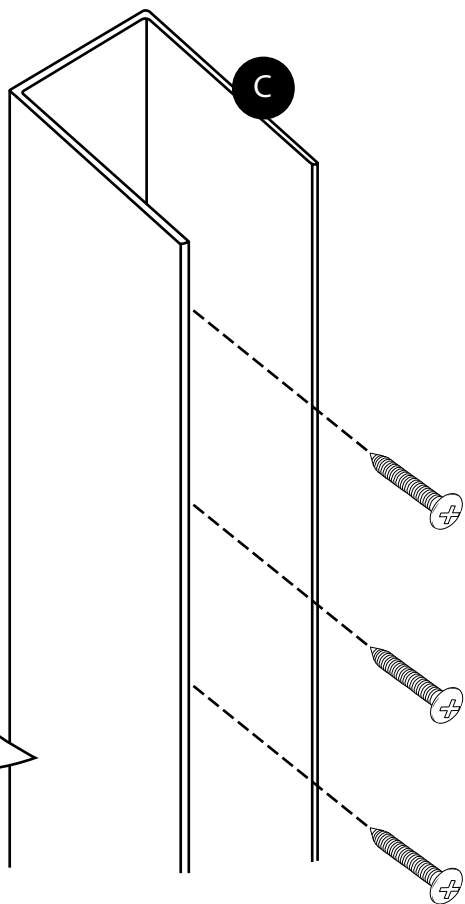
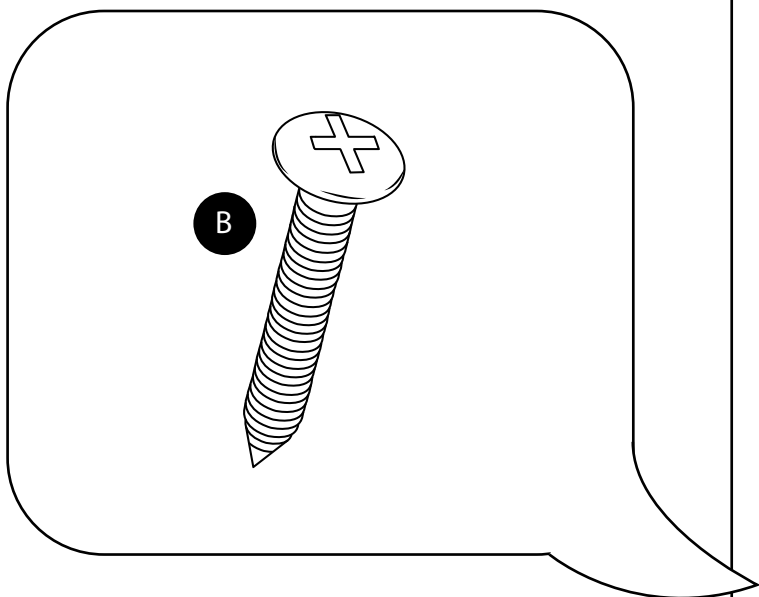

5

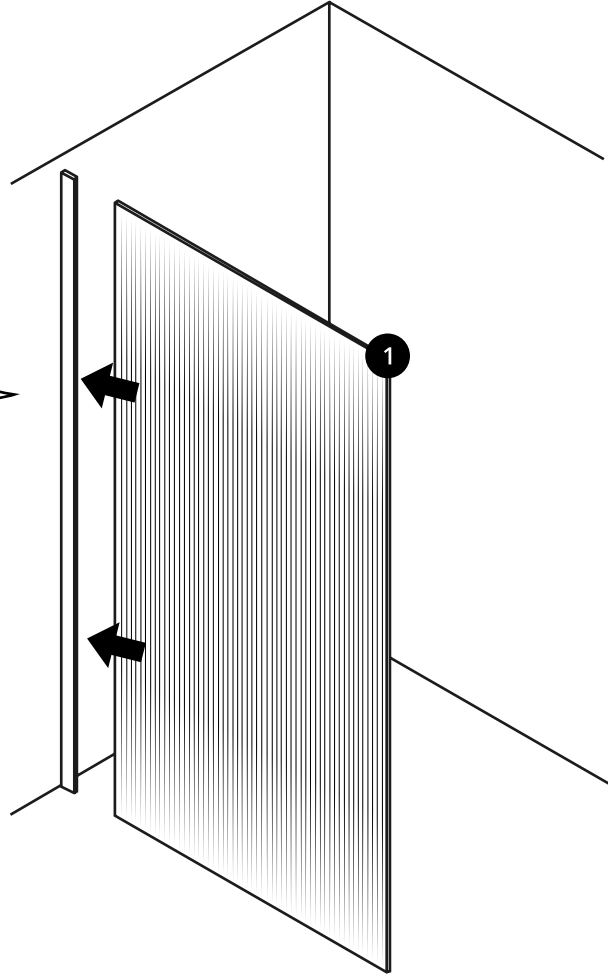
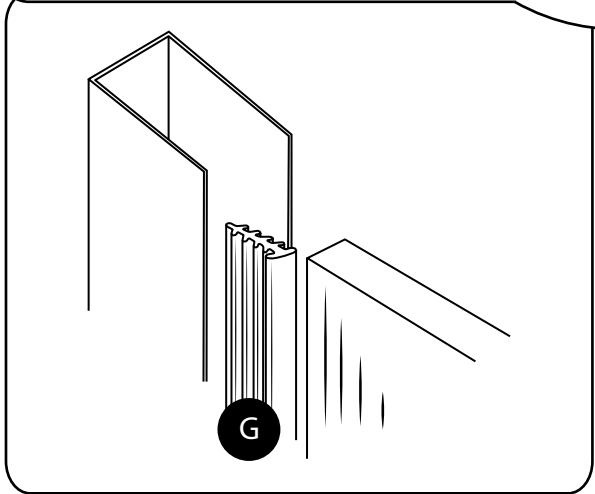
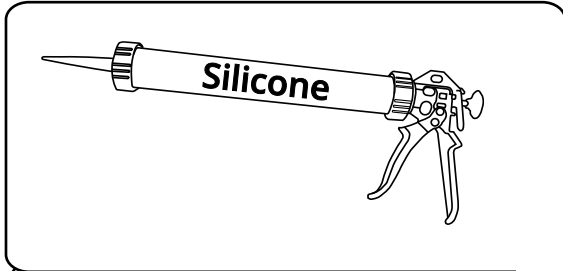

6

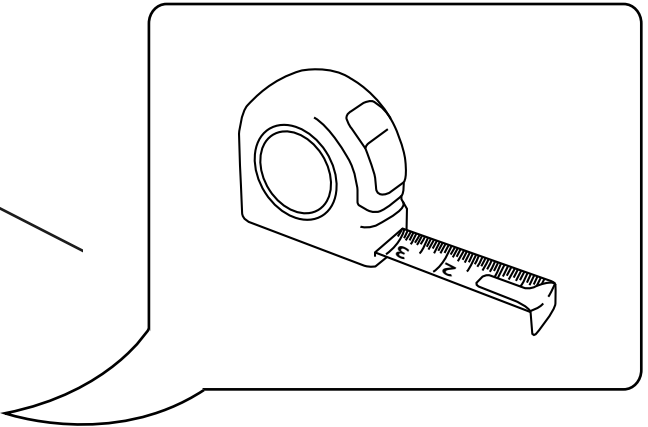
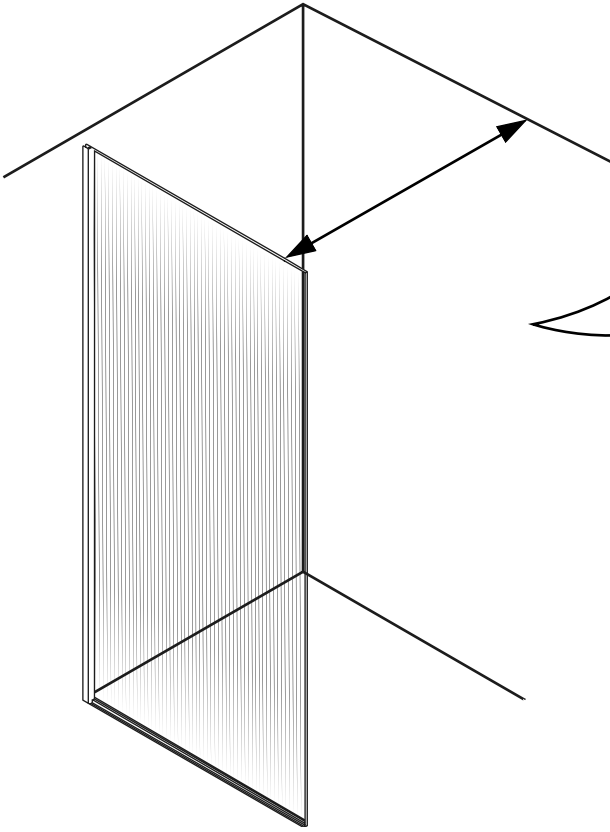

7

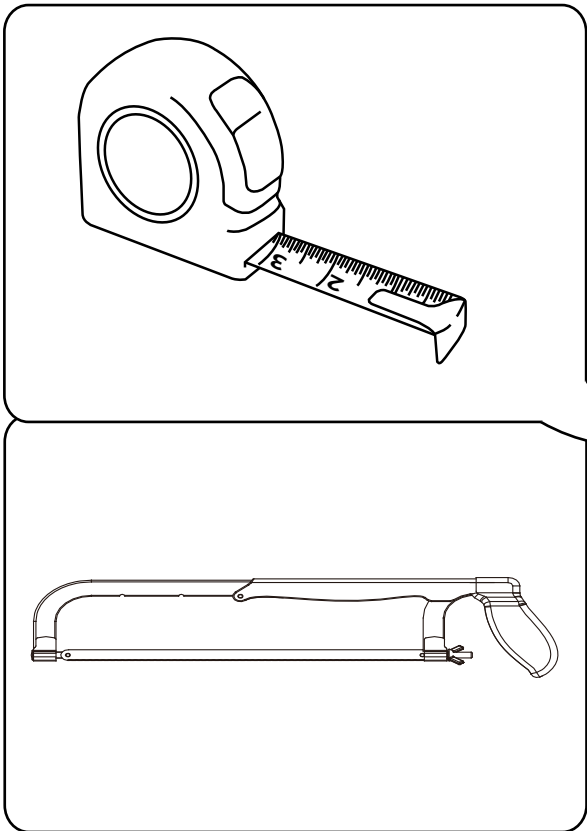

8

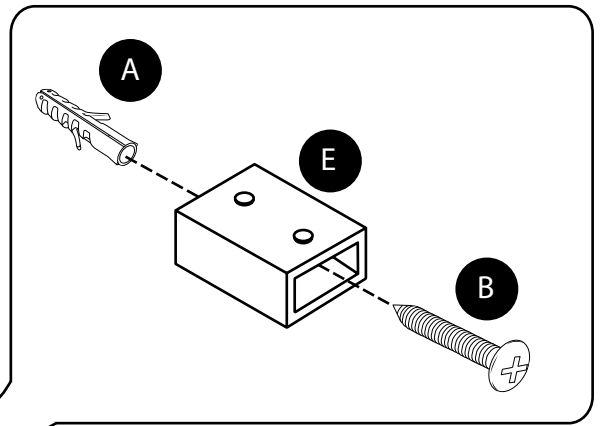
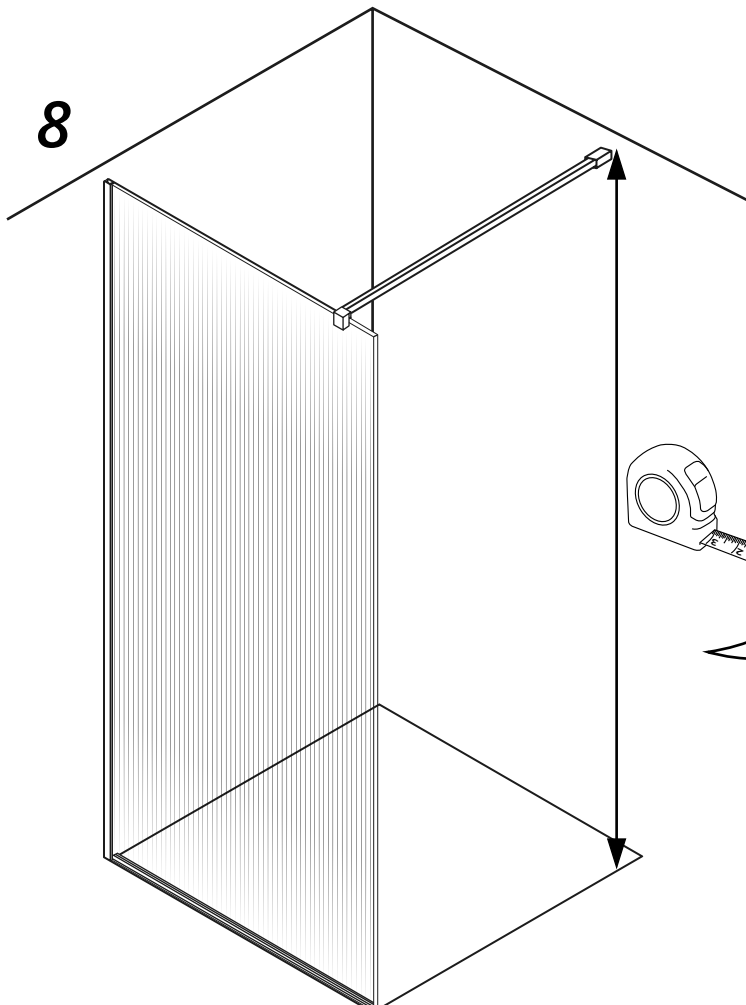

9

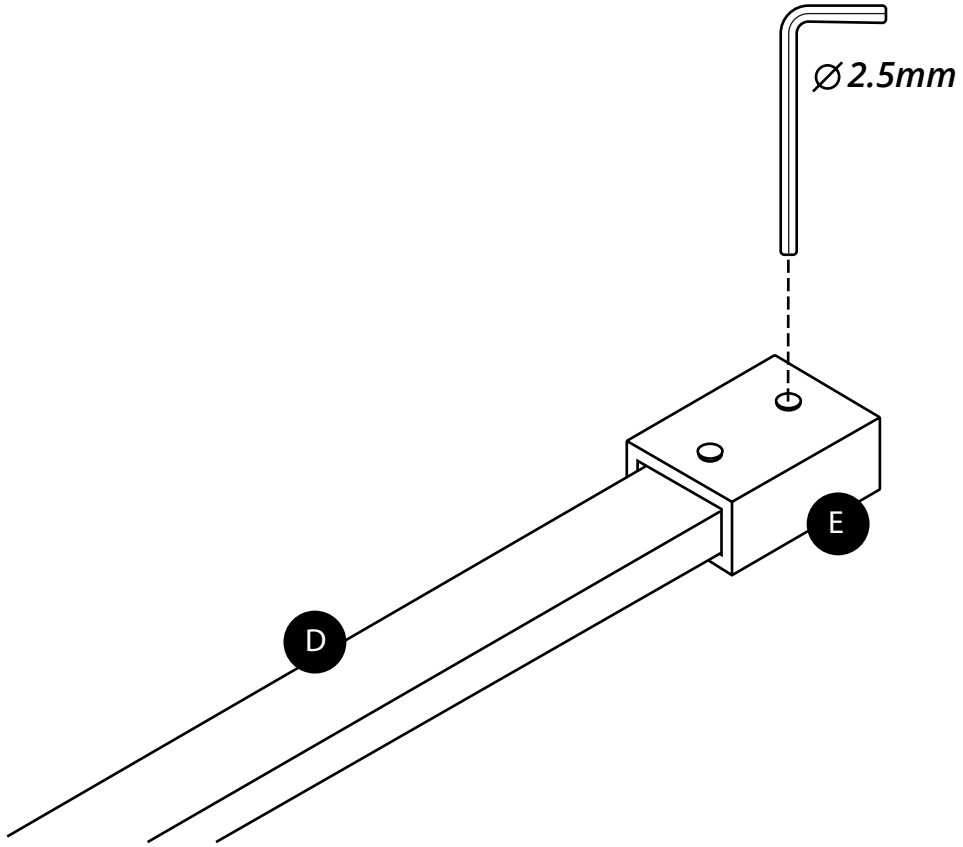

10

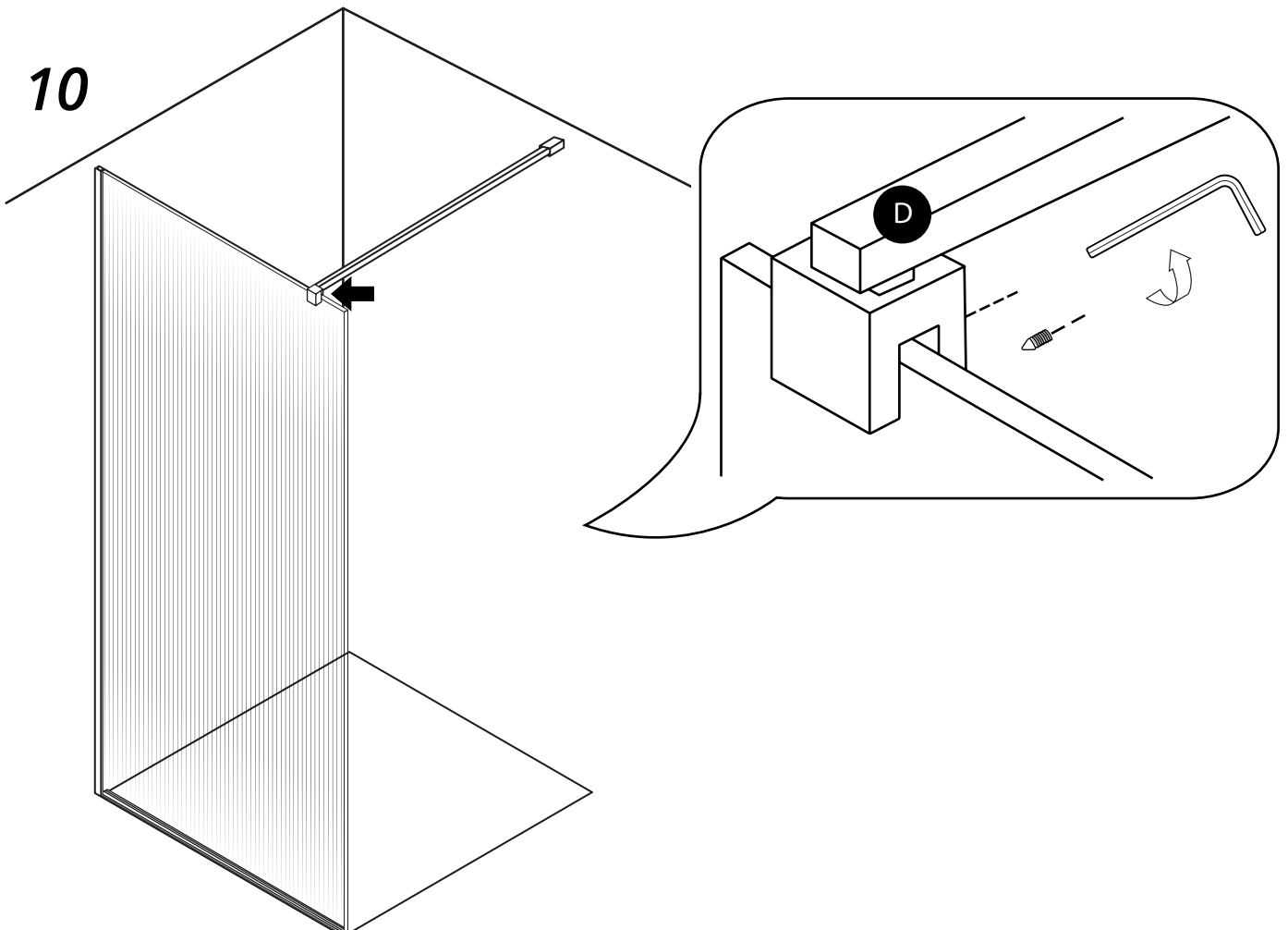

11

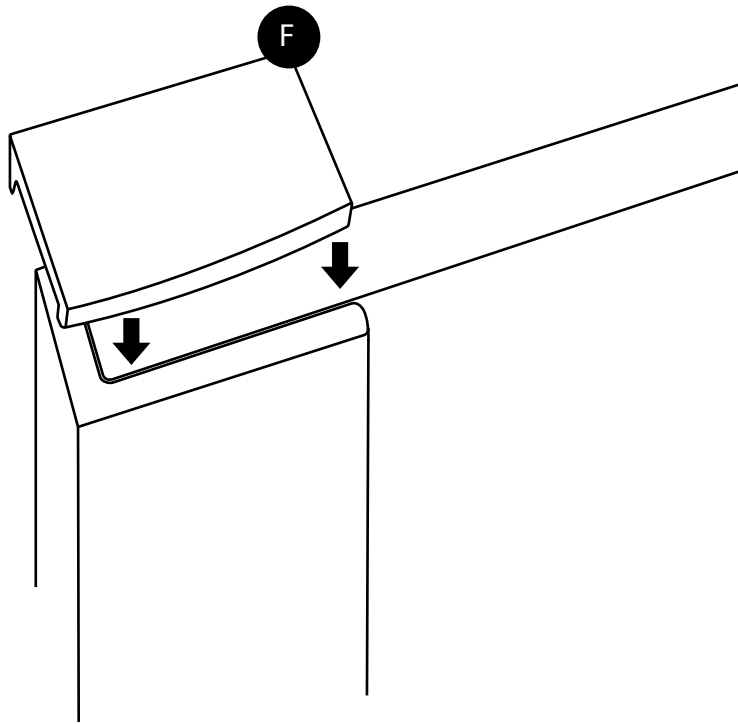

Opzionale: supporto

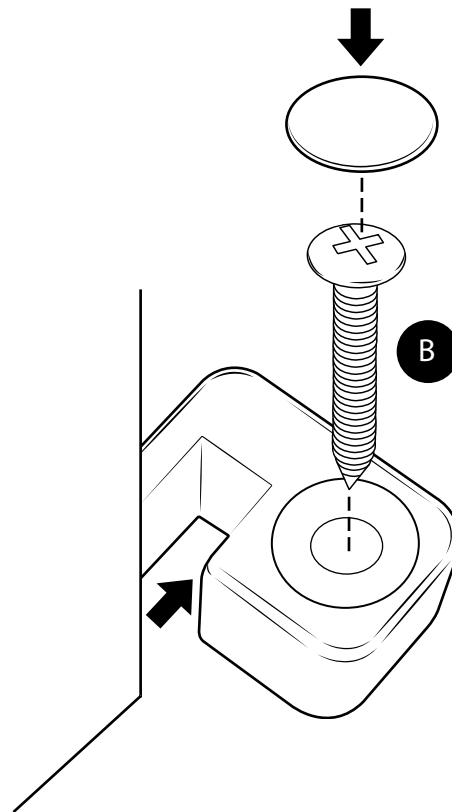
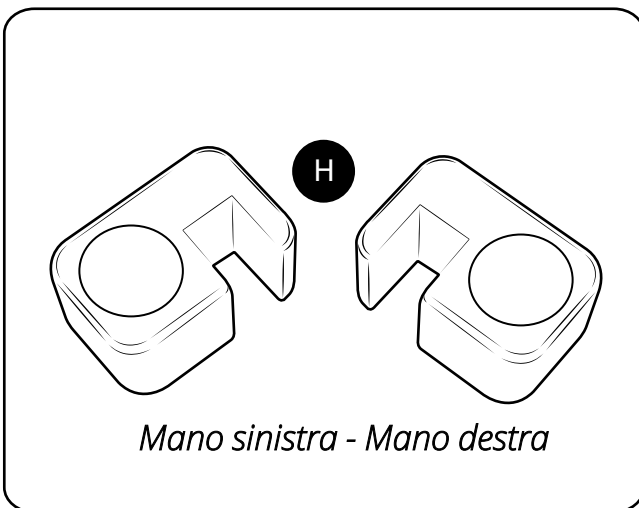

12

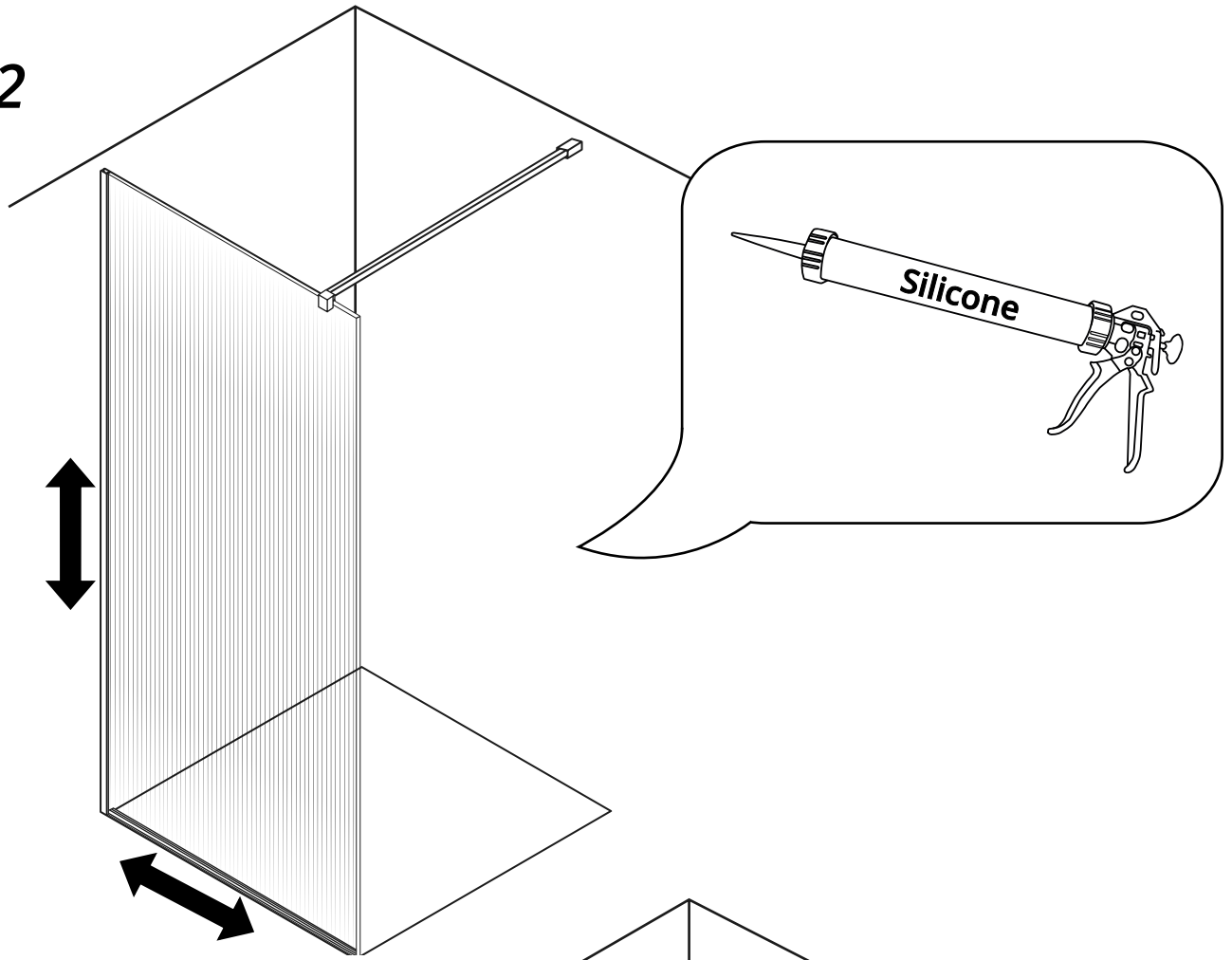

13

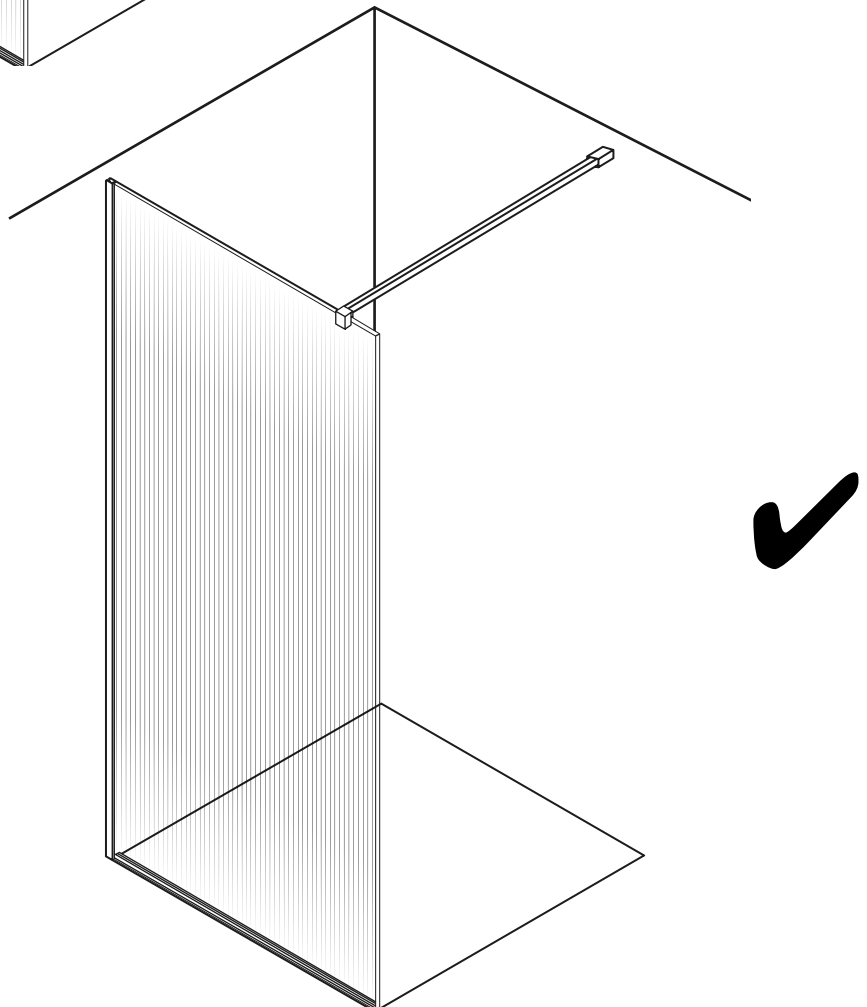

Manutenzione e Pulizia



Pulire immediatamente eventuali perdite:

